

LMH6515

600 MHz, Digital Controlled, Variable Gain Amplifier

General Description

The LMH6515 is a high performance, digitally controlled variable gain amplifier (DVGA). It combines precision gain control with a low noise, ultra-linear, differential amplifier. Typically, the LMH6515 drives a high performance ADC in a broad range of mixed signal and digital communication applications such as mobile radio and cellular base stations where automatic gain control (AGC) is required to increase system dynamic range. When used in conjunction with a high speed ADC, system dynamic range can be extended by up to 32 dB.

The LMH6515 has a differential input and output allowing large signal swings on a single 5V supply. It is designed to accept signals from RF elements and maintain a terminated impedance environment. The input impedance is 200Ω resistive. The output impedance is either 200Ω or 400Ω and is user selectable. A unique internal architecture allows use with both single ended and differential input signals.

Input signals to the LMH6515 are scaled by a highly linear, digitally controlled attenuator with 31 accurate 1 dB steps. The attenuator output provides the input signal for a high gain, ultra linear differential transconductor. The transconductor differential output current can be converted into a voltage by using the on-chip 200Ω or 400Ω loads. The transconductance gain is 0.1 Amp/Volt resulting in a maximum voltage gain of +26 dB when driving a 200Ω load, or 32 dB when driving the 400Ω load. On chip digital latches are provided for local storage of the gain setting. The gain step settling time is 5 ns and care has been taken to reduce the sensitivity of bandwidth and phase to gain setting.

The LMH6515 operates over the industrial temperature range of -40°C to +85°C. The LMH6515 is available in a 16-Pin, thermally enhanced, LLP package.

Features

- Adjustable gain with a 31 dB range
- Precise 1 dB gain steps
- Parallel 5-bit gain control
- On chip register stores gain setting
- Fully differential signal path
- Single ended to differential capable
- 200Ω input impedance
- Small footprint (4 mm x 4 mm) LLP package

Key Specifications

- 600 MHz bandwidth @ 100Ω load
- 40 dBm OIP3 @ 75 MHz, 200Ω load
- 20 dB to 30 dB maximum gain
- Selectable output impedance of 200Ω or 400Ω
- 8.3 dB noise figure
- 5 ns gain step switching time
- 100 mA supply current

Applications

- Cellular base stations
- IF sampling receivers
- Instrumentation
- Modems
- Imaging
- Differential line receiver

Typical Application

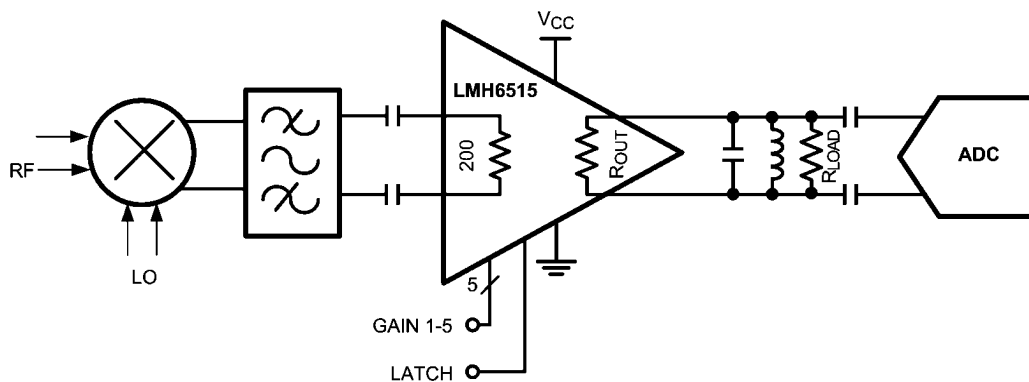

20214301

Absolute Maximum Ratings (Note 1)

If Military/Aerospace specified devices are required, please contact the National Semiconductor Sales Office/Distributors for availability and specifications.

ESD Tolerance (Note 2)	
Human Body Model	2 kV
Machine Model	150V
Positive Supply Voltage (Pin 3)	-0.6V to 5.5V
Output Voltage (pin 14,15)	-0.6V to 6.8V
Differential Voltage Between Any Two Grounds	<200 mV
Analog Input Voltage Range	-0.6V to V_{CC}
Digital Input Voltage Range	-0.6V to 3.6V
Output Short Circuit Duration (one pin to ground)	Infinite
Junction Temperature	+150°C

Storage Temperature Range	-65°C to +150°C
Soldering Information	
Infrared or Convection (20 sec)	235°C
Wave Soldering (10 sec)	260°C

Operating Ratings (Note 1)

Supply Voltage (Pin 3)	4V to 5.25V
Output Voltage Range (Pin 14, 15)	1.4V to 6.4V
Differential Voltage Between Any Two Grounds	<10 mV
Analog Input Voltage Range, AC Coupled	±1.4V
Temperature Range (Note 3)	-40°C to +85°C
Package Thermal Resistance (θ_{JA})	
16-Pin LLP	47°C/W

5V Electrical Characteristics (Note 4)

The following specifications apply for single supply with $V_{CC} = 5V$, Maximum Gain, $R_L = 100\Omega$ (200 Ω external || 200 Ω internal), $V_{OUT} = 2 V_{PP}$, $f_{in} = 150$ MHz. Boldface limits apply at temperature extremes.

Symbol	Parameter	Conditions	Min (Note 6)	Typ (Note 5)	Max (Note 6)	Units
Dynamic Performance						
SSBW	-3 dB Bandwidth	Average of all Gain Settings		600		MHz
Noise and Distortion						
	Third Order Intermodulation Products	f = 75 MHz, $V_{OUT} = 2 V_{PP}$		-76		dBc
		f = 150 MHz, $V_{OUT} = 2 V_{PP}$		-72		
		f = 250 MHz, $V_{OUT} = 2 V_{PP}$		-66		
		f = 450 MHz, $V_{OUT} = 2 V_{PP}$		-58		
OIP3	Output 3rd Order Intercept Point	f = 75 MHz, $V_{OUT} = 2 V_{PP}$, Tone Spacing = 0.5 MHz		39		dBm
		f = 150 MHz, $V_{OUT} = 2 V_{PP}$, Tone Spacing = 2 MHz		37		
		f = 250 MHz, $V_{OUT} = 2 V_{PP}$, Tone Spacing = 2 MHz		34		
		f = 75 MHz, $R_L = 200\Omega$, $V_{OUT} = 2 V_{PP}$, Tone Spacing = 0.5 MHz		40		
		f = 150 MHz, $R_L = 200\Omega$, $V_{OUT} = 2 V_{PP}$, Tone Spacing = 2 MHz		37		
		f = 250 MHz, $R_L = 200\Omega$, $V_{OUT} = 2 V_{PP}$, Tone Spacing = 2 MHz		34		
P1 dB	Output Level for 1 dB Gain Compression	f = 75 MHz, $R_L = 200\Omega$		16.7		dBm
		f = 250 MHz, $R_L = 200\Omega$		14.7		
		f = 75 MHz		14.5		
		f = 450 MHz		13.2		
VNI	Input Noise Voltage	Maximum Gain, f = 40 MHz		1.8		nV/\sqrt{Hz}
VNO	Output Noise Voltage	Maximum Gain, f = 40 MHz		18		nV/\sqrt{Hz}
NF	Noise Figure	Maximum Gain		8.3		dB
Analog I/O						
	Differential Input Resistance		165 160	186	210 220	Ω
	Input Common Mode Resistance		825 785	971	1120 1160	Ω

Symbol	Parameter	Conditions	Min (Note 6)	Typ (Note 5)	Max (Note 6)	Units
	Differential Output Impedance	Low Gain Option		187		Ω
		High Gain Option	330 325	370	410 415	
	Internal Load Resistors	Between Pins 13, 14 and Pins 15, 16	165 160	187	210 235	Ω
	Input Signal Level (AC Coupled)	Max Gain, $V_O = 2 V_{PP}$, $R_L = 1 k\Omega$		126		mV _{PP}
	Maximum Differential Input Signal	AC Coupled		5.6		V _{PP}
	Input Common Mode Voltage	Self Biased	1.3 1.1	1.4	1.5 1.7	V
	Input Common Mode Voltage Range	Driven Externally		0.9 to 2.0		V
	Minimum Input Voltage	DC		0		V
	Maximum Input Voltage	DC		3.3		V
	Maximum Differential Output Voltage Swing	$V_{CC} = 5V$, Output Common Mode = 5V		5.5		V _{PP}
V _{OS}	Output Offset Voltage	All Gain Settings		30		mV
CMRR	Common Mode Rejection Ratio			85		dB
PSRR	Power Supply Rejection Ratio		63 61	83		dB
Gain Parameters						
	Maximum Gain	DC, Internal $R_L = 200\Omega$, External $R_L = 1280\Omega$	23.9 23.4	24.2	24.6 24.8	dB
	Minimum Gain	DC, Internal $R_L = 200\Omega$, External $R_L = 1280\Omega$	-7.2 -7.7	-6.9	-6.5 -6.4	dB
	Gain Step Size	DC		1.0		dB
	Gain Step Error	DC		0.02		dB
		f = 150 MHz		0.07		
	Cumulative Gain Step Error	DC, Gain Step 31 to Gain Step 0	-0.1 -0.2	0.05	0.3 0.4	dB
	Gain Step Switching Time			5		ns
Digital Inputs/Timing						
	Logic Compatibility	CMOS Logic		3.3		V
V _{IL}	Logic Input Low Voltage				0.8	V
V _{IH}	Logic Input High Voltage		2.0			V
I _{IH}	Logic Input High Input Current			32	40	μA
TSU	Setup Time			3		ns
THOLD	Hold Time			3		ns
TPW	Minimum Latch Pulse Width			10		ns
Power Requirements						
ICC	Total Supply Current	$V_{OUT} = 0V$ Differential, V_{OUT} Common Mode = 5V		107	124 134	mA
	Amplifier Supply Current	Pin 3 Only		56	66 74	mA
	Output Stage Bias Currents	Pins 13, 14 and Pins 15, 16; V_{OUT} Common Mode = 5 V		48	58 60	mA

Note 1: Absolute Maximum Ratings indicate limits beyond which damage to the device may occur. Operating Ratings indicate conditions for which the device is intended to be functional, but specific performance is not guaranteed. For guaranteed specifications, see the Electrical Characteristics tables.

Note 2: Human Body Model, applicable std. MIL-STD-883, Method 3015.7. Machine Model, applicable std. JESD22-A115-A (ESD MM std. of JEDEC) Field-Induced Charge-Device Model, applicable std. JESD22-C101-C (ESD FICDM std. of JEDEC).

Note 3: The maximum power dissipation is a function of $T_{J(MAX)}$, θ_{JA} . The maximum allowable power dissipation at any ambient temperature is $P_D = (T_{J(MAX)} - T_A) / \theta_{JA}$. All numbers apply for packages soldered directly onto a PC Board.

Note 4: Electrical Table values apply only for factory testing conditions at the temperature indicated. No guarantee of parametric performance is indicated in the electrical tables under conditions different than those tested

Note 5: Typical values represent the most likely parametric norm as determined at the time of characterization. Actual typical values may vary over time and will also depend on the application and configuration. The typical values are not tested and are not guaranteed on shipped production material.

Note 6: Limits are 100% production tested at 25°C. Limits over the operating temperature range are guaranteed through correlation using Statistical Quality Control (SQC) methods.

Note 7: Negative input current implies current flowing out of the device.

Note 8: Drift determined by dividing the change in parameter at temperature extremes by the total temperature change.

Connection Diagram

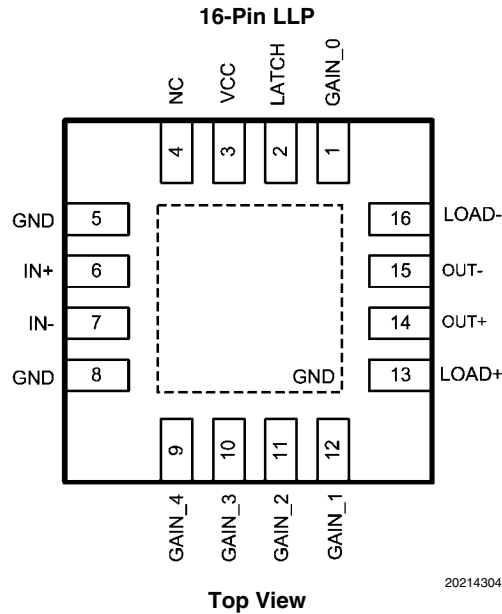

Gain Control Pins

Pin Number	Pin Name	Gain Step Size
1	GAIN_0	1 dB
12	GAIN_1	2 dB
11	GAIN_2	4 dB
10	GAIN_3	8 dB
9	GAIN_4	16 dB

Ordering Information

Package	Part Number	Package Marking	Transport Media	NSC Drawing
16-Pin LLP	LMH6515SQ	L6515SQ	1k Units Tape and Reel	SQA16A
	LMH6515SQX		4.5k Units Tape and Reel	

Pin Descriptions

Pin Number	Symbol	Description
Analog I/O		
6	IN+	Non-inverting analog input. Internally biased to 1.4V. Input voltage should not exceed V_{CC} or go below GND by more than 0.5V.
7	IN-	Inverting analog input. Internally biased to 1.4V. Input voltage should not exceed V_{CC} or go below GND by more than 0.5V. If using amplifier single ended this input should be capacitively coupled to ground.
15	OUT-	Open collector inverting output. This pin is an output that also requires a power source. This pin should be connected to 5V through either an RF choke or an appropriately sized inductor that can form part of a filter. See application section for details.
14	OUT+	Open collector non-inverting output. This pin is an output that also requires a power source. This pin should be connected to 5V through either an RF choke or an appropriately sized inductor that can form part of a filter. See application section for details.
16	LOAD-	Internal 200 Ω resistor connection to pin 15. This pin can be left floating for higher gain or shorted to pin 13 for lower gain and lower effective output impedance. See application section for details.
13	LOAD+	Internal 200 Ω resistor connection to pin 14. This pin can be left floating for higher gain or shorted to pin 16 for lower gain and lower effective output impedance. See application section for details.
Power		
3	V_{CC}	5V power supply pin. Use ceramic, low ESR bypass capacitors. This pin powers everything except the output stage.
5,8	GND	Ground pins. Connect to low impedance ground plane. All pin voltages are specified with respect to the voltage on these pins. The exposed thermal pad is also a ground connection.
Digital Inputs		
1,12,11, 10,9	GAIN_0 to GAIN_4	Gain setting pins. See above table for gain step sizes for each pin. These pins are 3.3V CMOS logic compatible. 5V inputs may cause damage.
2	LATCH	This pin controls the function of the gain setting pins mentioned above. With LATCH in the logic HIGH state the gain is fixed and will not change. With the LATCH in the logic LOW state the gain is set by the state of the gain control pins. Any changes in gain made with the LATCH pin in the LOW state will take effect immediately. This pin is 3.3V CMOS logic compatible. 5V inputs may cause damage.
4	NC	This pin is not connected. It can be grounded or left floating.

Typical Performance Characteristics $V_{CC} = 5V$

Frequency Response All Gain Settings

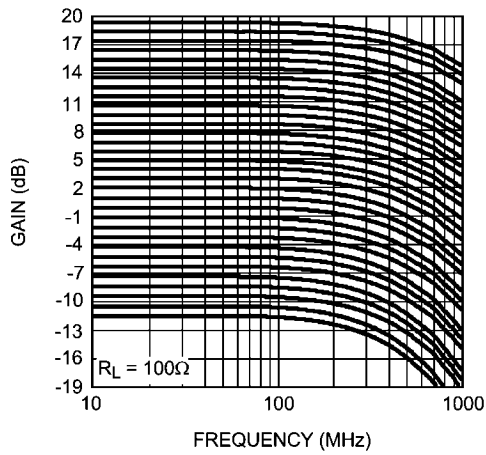

20214322

Frequency Response with Capacitive Load

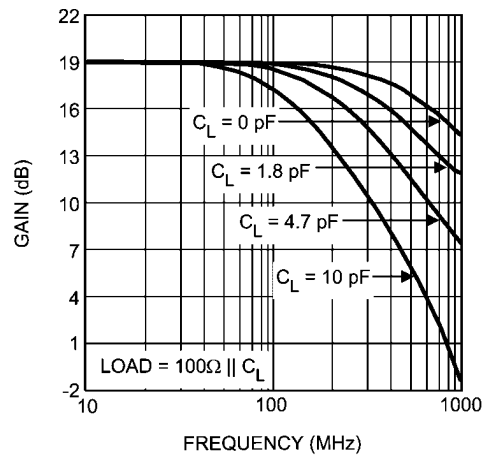

20214325

Frequency Response Over Temperature, Maximum Gain

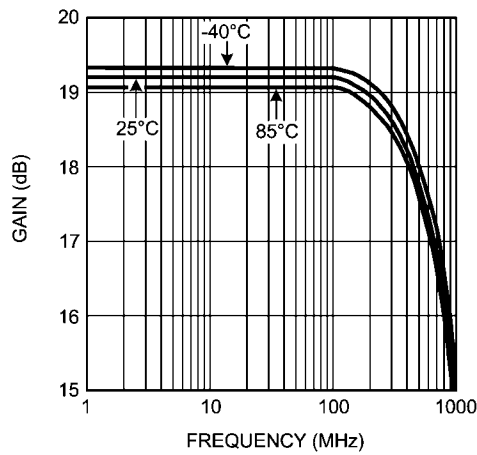

20214349

Frequency Response Over Temperature, Minimum Gain

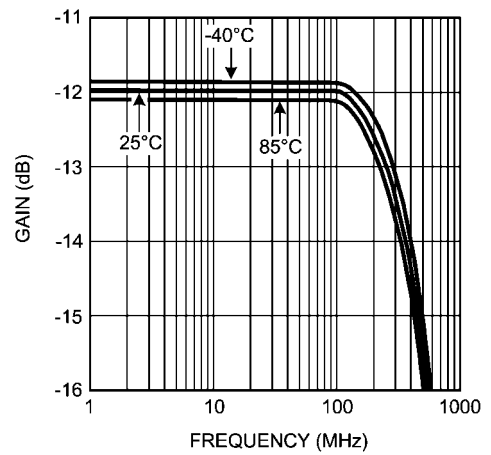

20214350

OIP3 High Gain Mode

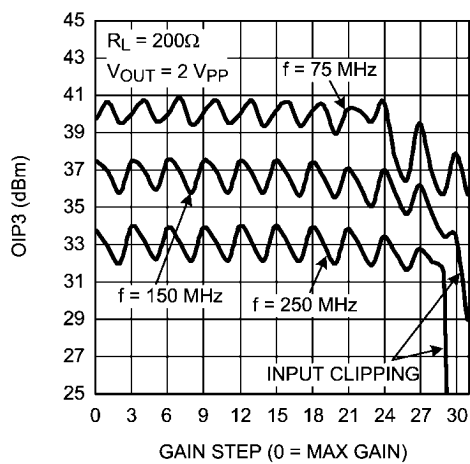

20214343

OIP3 Low Gain Mode

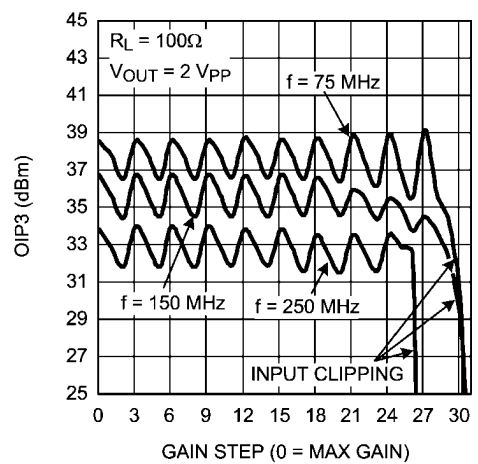

20214342

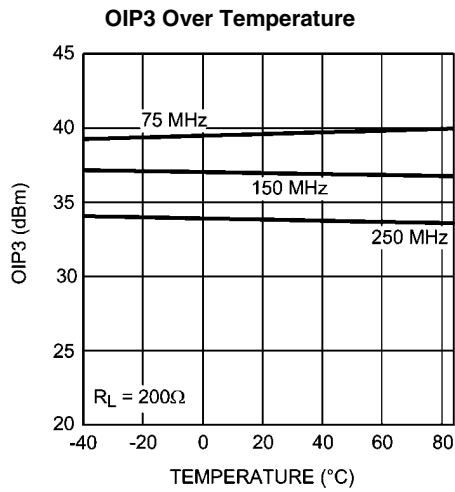

20214326

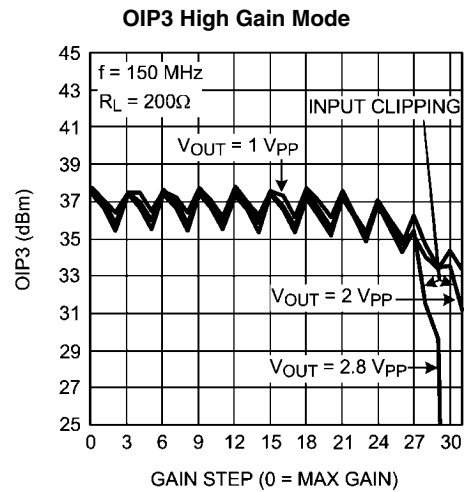

20214324

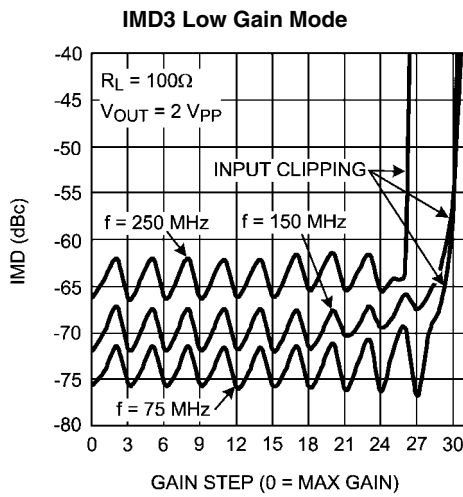

20214340

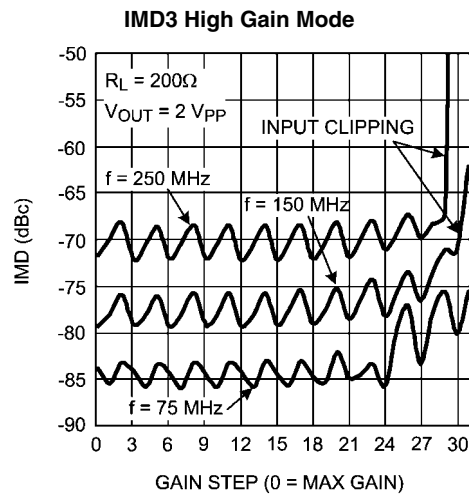

20214341

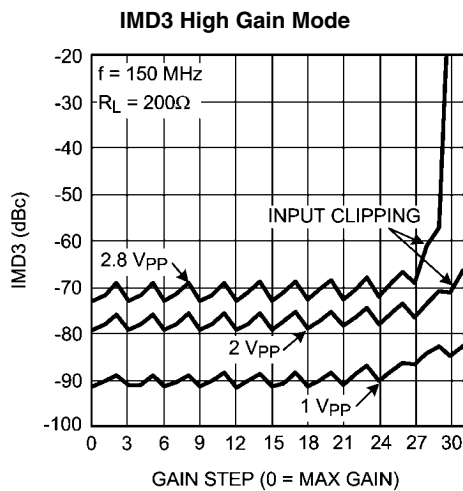

20214323

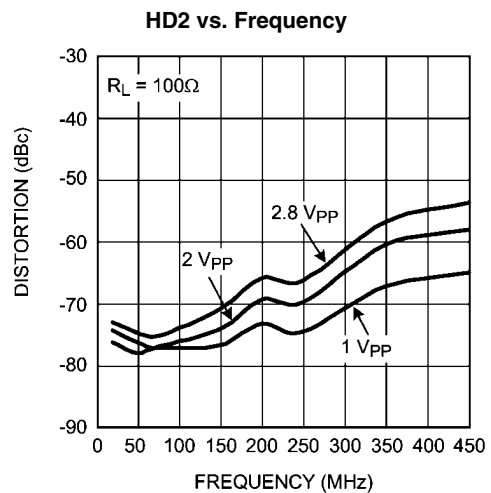

20214336

HD3 vs. Frequency

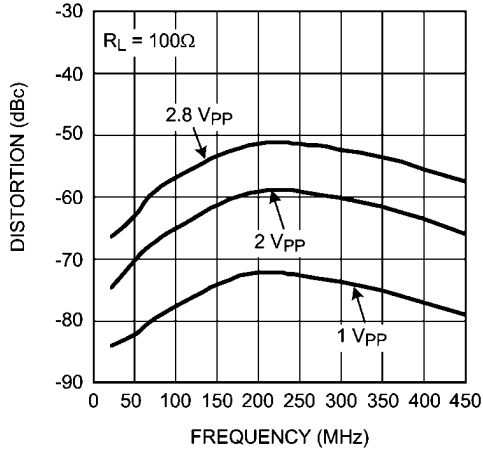

20214339

HD2 vs. Frequency

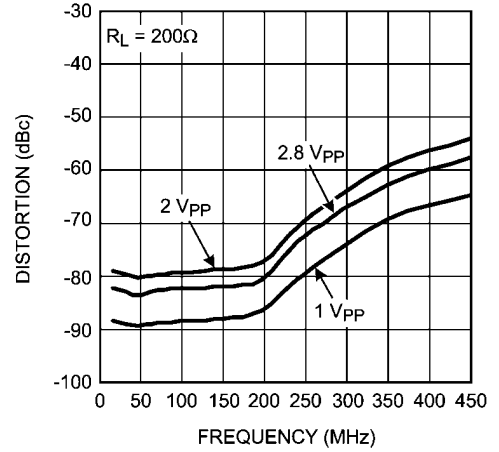

20214338

HD3 vs. Frequency

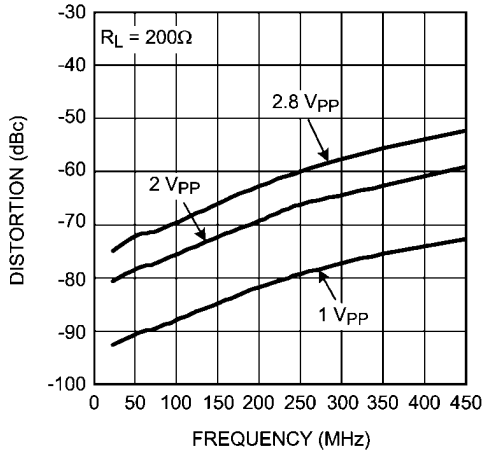

20214337

Noise Figure for All Gain Settings

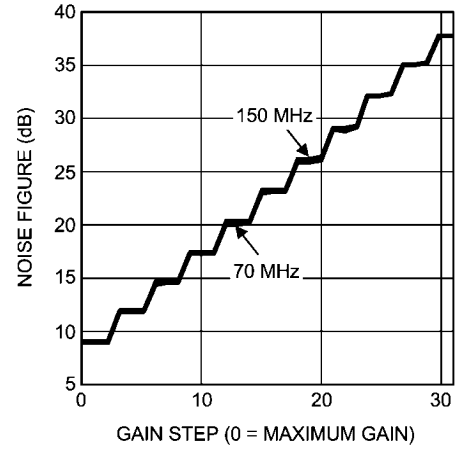

20214314

Noise Figure vs. Frequency

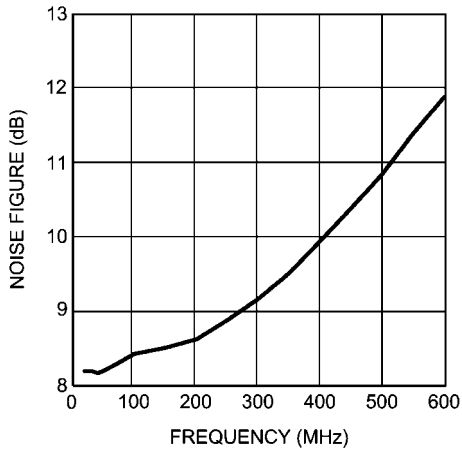

20214317

Differential Output Noise

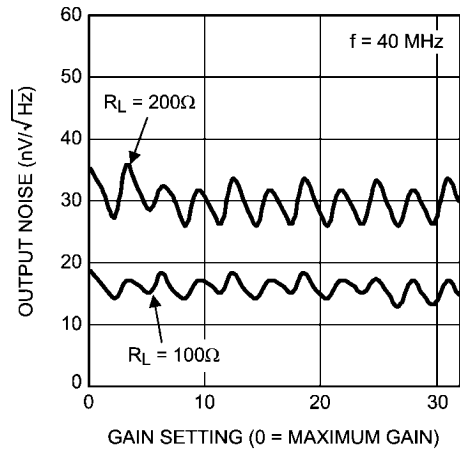

20214318

Maximum Gain vs. Supply Voltage

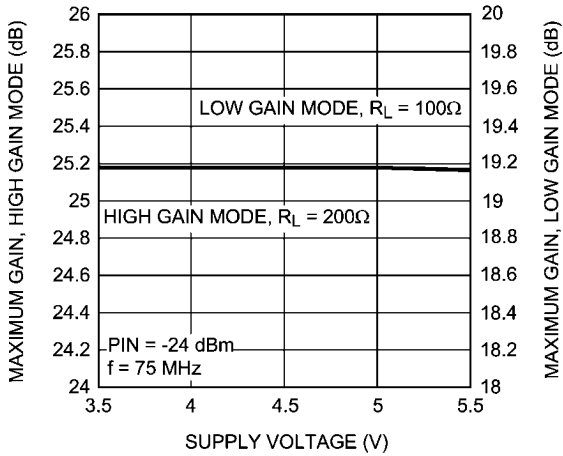

20214327

Gain vs. External Load

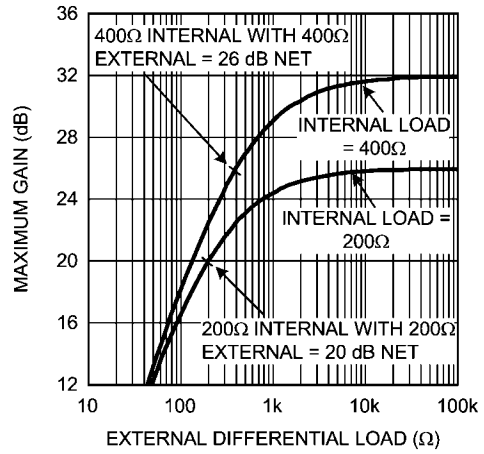

20214312

Maximum Gain Over Temperature

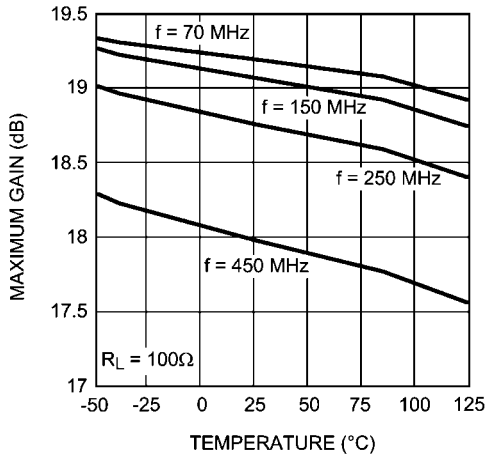

20214344

Worst Case Gain Step Error vs. Frequency

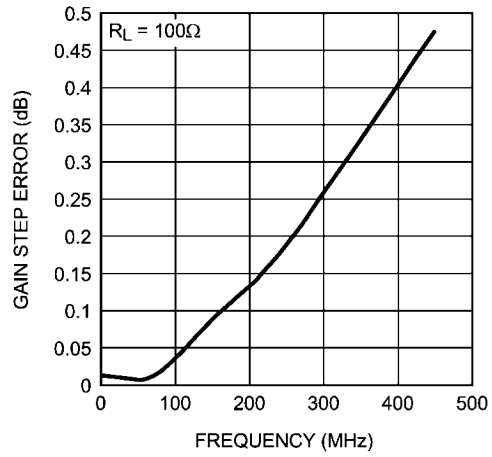

20214345

Worst Case Gain Step Error vs. Frequency

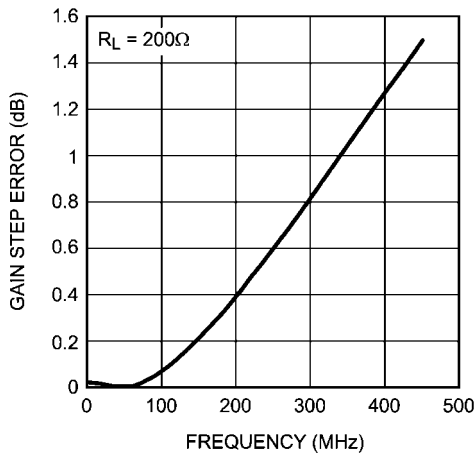

20214346

Worst Case Gain Step Error Over Temperature

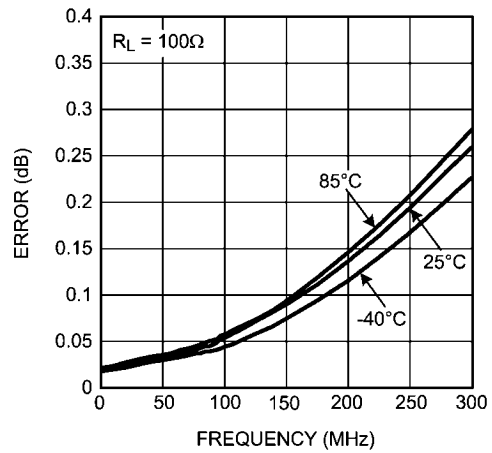

20214351

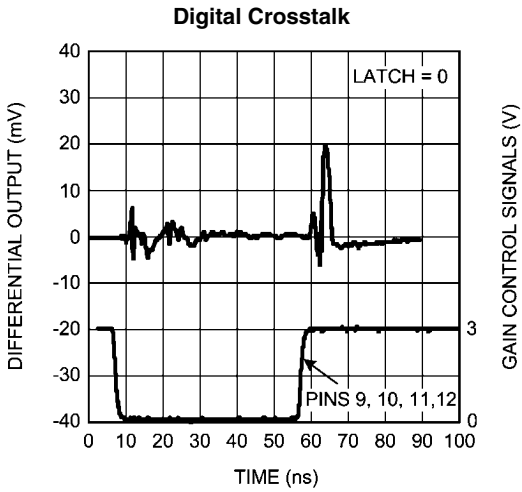

20214347

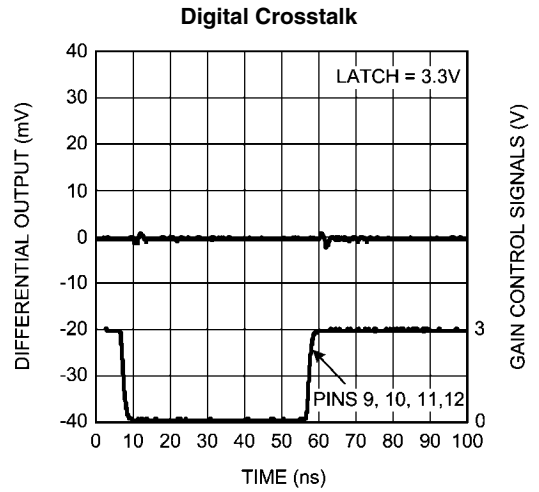

20214348

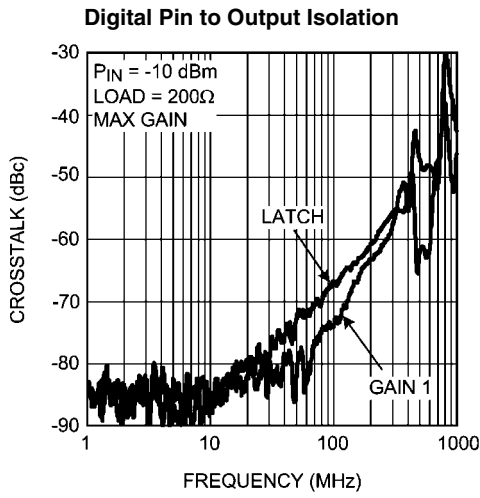

20214319

Minimum Gain to Maximum Gain Switching Using Latch Pin

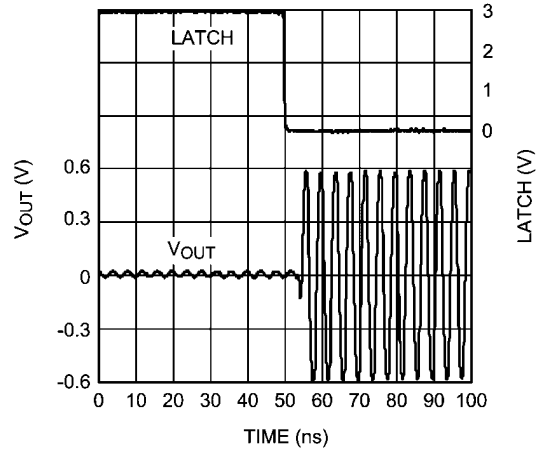

20214330

Maximum Gain to Minimum Gain Switching Using Latch Pin

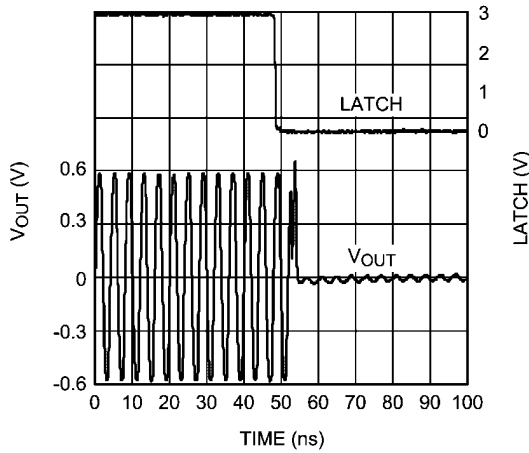

20214335

16 dB Gain Step Using Latch Pin

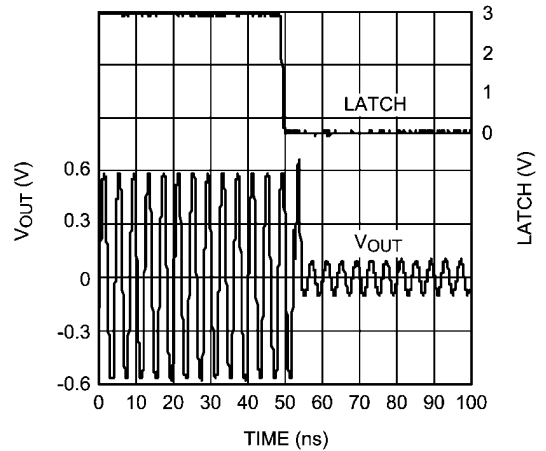

20214332

16 dB Gain Step with Latch Pin Low
Switching Gain Pin 4

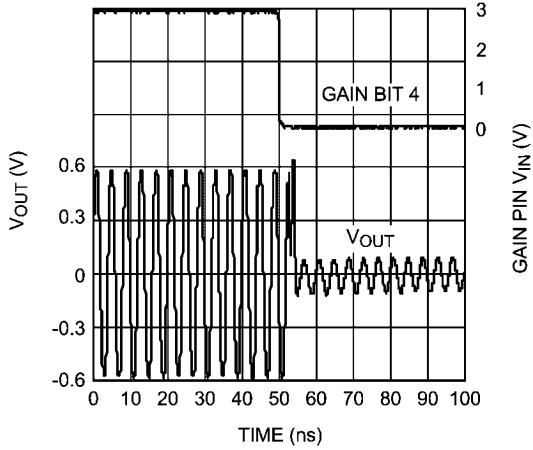

20214329

8 dB Gain Step with Latch Pin Low
Switching Gain Pin 3

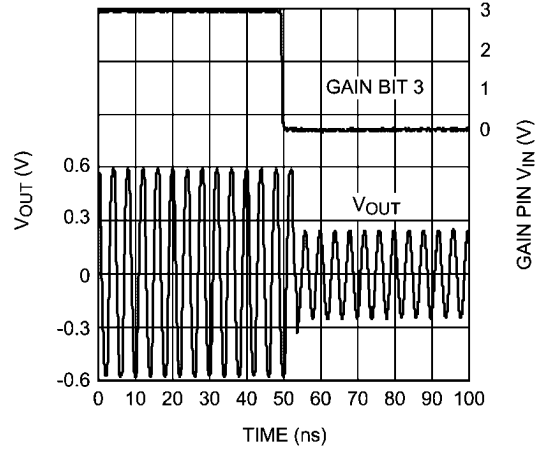

20214328

4 dB Gain Step Using Latch Pin

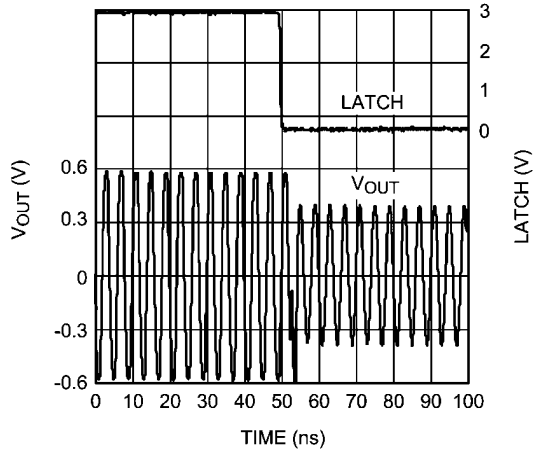

20214333

Power On Timing, Maximum Gain

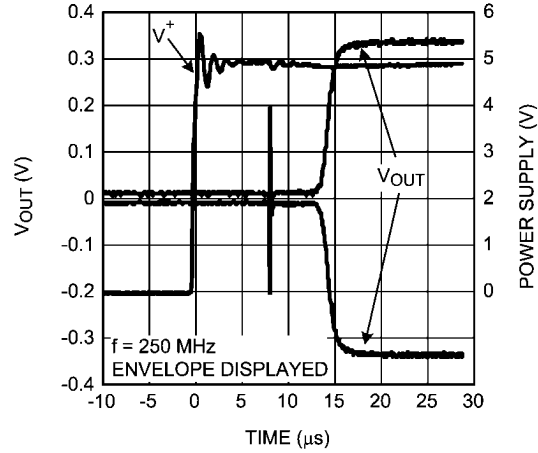

20214353

Power On Timing, Minimum Gain

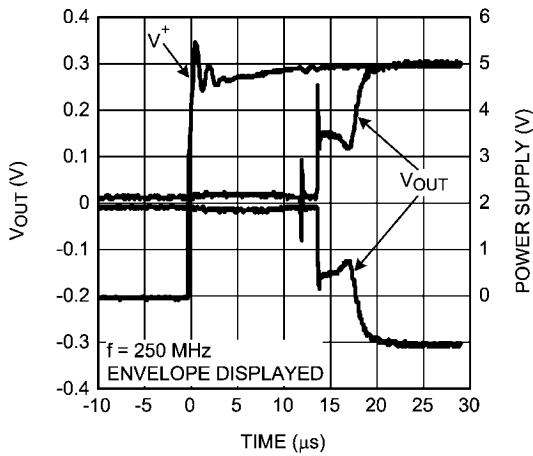

20214354

Power Off Timing, Maximum Gain

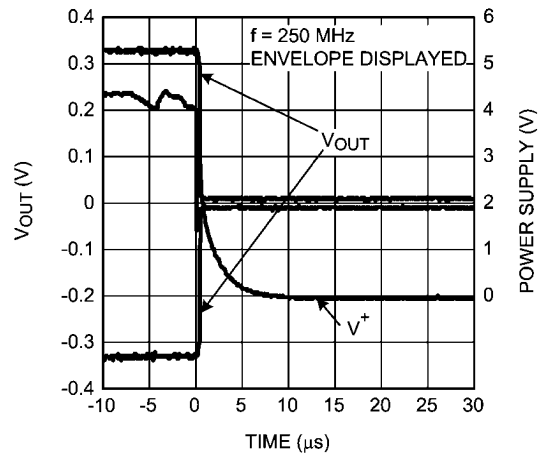

20214356

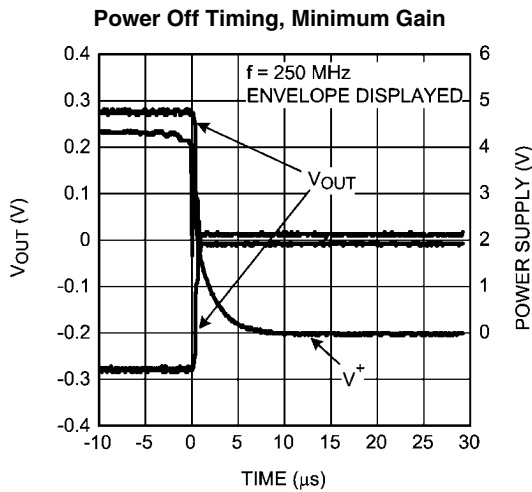

20214355

Application Information

The LMH6515 is a fully differential amplifier optimized for signal path applications up to 400 MHz. The LMH6515 has a 200Ω input. The absolute gain is load dependent, however the gain steps are always 1 dB. The LMH6515 output stage is a class A amplifier. This class A operation results in excellent distortion and linearity characteristics. This makes the LMH6515 ideal for voltage amplification and an ideal ADC driver where high linearity is necessary.

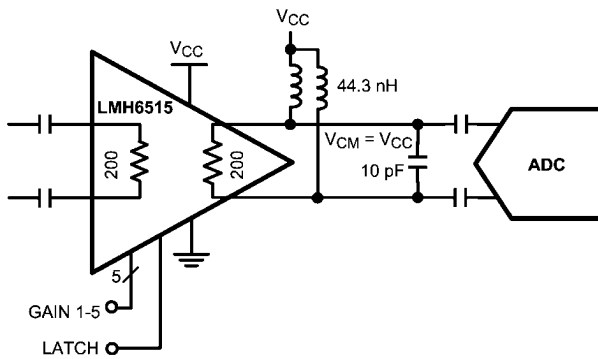

20214303

FIGURE 1. LMH6515 Typical Application

The LMH6515 output common mode should be set carefully. Using inductors to set the output common mode is one preferred method and will give maximum output swing. AC coupling of the output is recommended. The inductors mentioned above will shift the idling output common mode to the positive supply. Also, with the inductors, the output voltage can exceed the supply voltage. Other options for setting the output common mode require supply voltages above 5V. If using a supply higher than 5V care should be taken to make sure the output common mode does not exceed the 5.25V supply rating.

It is also important to note the maximum voltage limits for the OUT+ and OUT- pins, which is 6.4V. When using inductors these pins will experience voltage swings beyond the supply voltage. With a 5V output common mode operating point this makes the effective maximum swing 5.6 V_{PP} differential. System calibration and automatic gain control algorithms should be tailored to avoid exceeding this limit.

In order to help with system design National Semiconductor offers the ADC14V155KDRB High IF Receiver reference design board. This board combines the LMH6515 DVGA with the ADC14V155 ADC and provides a ready made solution for many IF receiver applications. Using an IF frequency of 169 MHz it achieves a small signal SNR of 72 dBFS and an SFDR of greater than 90 dBFS. Large signal measurements show an SNR of 68 dBFS and an SFDR of 77 dBFS. The High IF Receiver board also features the LMK03000 low-jitter precision clock conditioner.

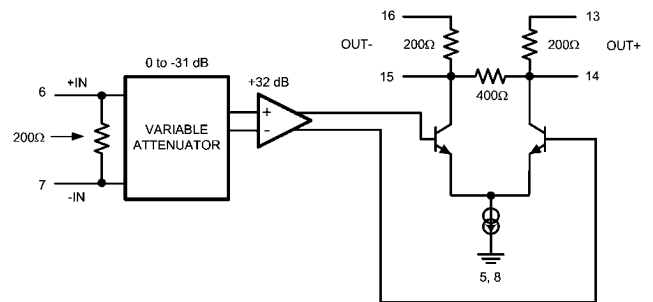

20214311

FIGURE 2. LMH6515 Block Diagram

INPUT CHARACTERISTICS

The LMH6515 input impedance is set by internal resistors to a nominal 200Ω. Process variations will result in a range of values as shown in the 5V Electrical Characteristics table. At higher frequencies parasitics will start to impact the impedance. This characteristic will also depend on board layout and should be verified on the customer's system board.

At maximum gain the digital attenuator is set to 0 dB and the input signal will be much smaller than the output. At minimum gain the output is 12 dB or more smaller than the input. In this configuration the input signal size may limit the amplifier output amplitude, depending on the output configuration and the desired output signal voltage. The input signal cannot swing more than 0.5V below the negative supply voltage (normally 0V) nor should it exceed the positive supply voltage. The input signal will clip and cause severe distortion if it is too large. Because the input stage self biases to approximately 1.4V the lower supply voltage will impose the limit for input voltage swing. To drive larger input signals the input common mode can be forced higher than 1.4V to allow for more swing. An

input common mode of 2.0V will allow an 8 V_{PP} maximum input signal. The trade off for input signal swing is that as the input common mode is shifted away from the 1.4V internal bias point the distortion performance will suffer slightly.

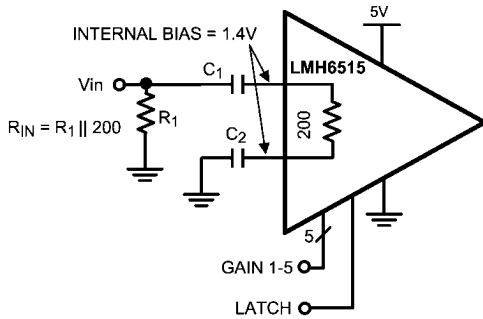

20214307

FIGURE 3. Single Ended Input (Note capacitor on grounded input)

OUTPUT CHARACTERISTICS

The LMH6515 has the option of two different output configurations. The LMH6515 is an open collector topology. As shown in *Figure 8* each output has an on chip 200Ω pull up resistor. In addition there is an internal 400Ω resistor between the two outputs. This results in a 200Ω or a 400Ω differential load in parallel with the external load. The 400Ω option is the high gain option and the 200Ω provides for less gain. The 200Ω configuration is recommended unless more gain is required.

The output common mode of the LMH6515 must be set by external components. Most applications will benefit from the use of inductors on the output stage. In particular, the 400Ω option, as shown in *Figure 9*, will require inductors in order to be able to develop an output voltage. The 200Ω option as shown in *Figure 10* or *Figure 11* will also require inductors since the voltage drop due to the on chip 200Ω resistors will saturate the output transistors. It is also possible to use resistors and high voltage power supplies to set the output common mode. This operation is not recommended, unless it is necessary to DC couple the output. If DC coupling is required the input common mode and output common mode voltages must be taken into account.

Maximum bandwidth with the LMH6515 is achieved by using the low gain, low impedance output option and using a low load resistance. With an effective load of 67Ω a bandwidth of nearly 1 GHz can be realized. As the effective resistance on the output stage goes up the capacitance of the board traces and amplifier output stage limit bandwidth in a roughly linear fashion. At an output impedance of 100Ω the bandwidth is down to 600 MHz, and at 200Ω the bandwidth is 260 MHz. For this reason driving very high impedance loads is not recommended.

Although bandwidth goes down with higher values of load resistance, the distortion performance improves and gain increases. The LMH6515 has a common emitter Class A output stage and minimizing the amount of current swing in the output devices improves distortion substantially.

The LMH6515 output stage is powered through the collectors of the output transistors. Power for the output stage is fed through inductors and the reactance of the inductors allows the output voltage to develop. In *Figure 1* the inductors are shown with a value of 44.4 nH. The value of the inductors used will be different for different applications. In *Figure 1* the

inductors have been chosen to resonate with the ADC and the load capacitor to provide a weak band pass filter effect. For broad band applications higher value inductors will allow for better low frequency operation. However, large valued inductors will reduce high frequency performance, particularly inductors of small physical sizes like 0603 or smaller. Larger inductors will tend to perform better than smaller ones of the same value even for narrow band applications. This is because the larger inductors will have a lower DC resistance and hence a higher Q and a higher self resonance frequency. The self resonance frequency should be higher than any desired signal content by at least a factor of two. Another consideration is that the power inductors and the filter inductors need to be placed on the circuit board such that their magnetic fields do not cause coupling. Mutual coupling of inductors can compromise filter characteristics and lead to unwanted distortion products.

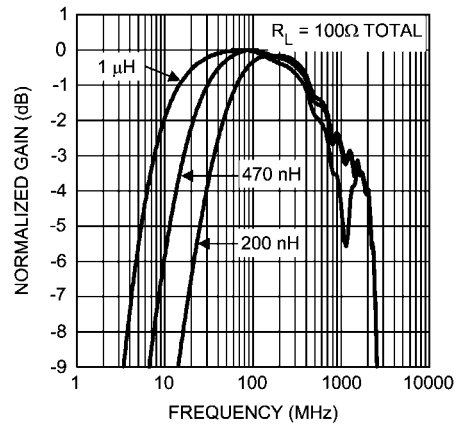

20214315

FIGURE 4. Bandwidth Changes Due to Different Inductor Values

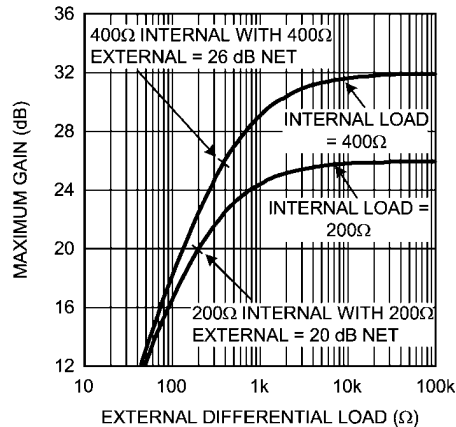

20214312

FIGURE 5. Gain vs. External Load

DIGITAL CONTROL

The LMH6515 has 32 gain settings covering a range of 31 dB. To avoid undesirable signal transients the LMH6515 should be powered on at the minimum gain state (all logic input pins at 0V). The LMH6515 has a 5-bit gain control bus as well as a latch pin. When the latch pin is low, data from the gain control pins is immediately sent to the gain circuit (i.e. gain is changed immediately). When the latch pin transitions high the

current gain state is held and subsequent changes to the gain set pins are ignored. To minimize gain change glitches multiple gain control pins should not change while the latch pin is low. In order to achieve the very fast gain step switching time of 5 ns the internal gain change circuit is very fast. Gain glitches could result from timing skew between the gain set bits. This is especially the case when a small gain change requires a change in state of three or more gain control pins. If continuous gain control is desired the latch pin can be tied to ground. This state is called transparent mode and the gain pins are always active. In this state the timing of the gain pin logic transitions should be planned carefully to avoid undesirable transients.

The LMH6515 was designed to interface with 3.3V CMOS logic circuits. If operation with 5V logic is required a simple voltage divider at each logic pin will allow for this. To properly terminate 100Ω transmission lines a divider with a 66.5Ω resistor to ground and a 33.2Ω series resistor will properly terminate the line as well as give the 3.3V logic levels. Care should be taken not to exceed the 3.6V absolute maximum voltage rating of the logic pins.

EXPOSED PAD LLP PACKAGE

The LMH6515 is in a thermally enhanced package. The exposed pad is connected to the GND pins. It is recommended, but not necessary, that the exposed pad be connected to the supply ground plane. In any case, the thermal dissipation of the device is largely dependent on the attachment of this pad. The exposed pad should be attached to as much copper on the circuit board as possible, preferably external copper. However, it is also very important to maintain good high speed layout practices when designing a system board. Please refer to the LMH6515 evaluation board for suggested layout techniques.

Package information is available on the National web site.
<http://www.national.com/packaging/folders/sqa16a.html>

INTERFACING TO ADC

The LMH6515 was designed to be used with high speed ADCs such as the ADC14155. As shown in the Typical Application schematic on page 1, AC coupling provides the best flexibility especially for IF sub-sampling applications. Any resistive networks on the output will also cause a gain loss because the output signal is developed across the output resistors. The chart *Maximum Gain vs. External Load* shows the change in gain when an external load is added.

The inputs of the LMH6515 will self bias to the optimum voltage for normal operation. The internal bias voltage for the inputs is approximately 1.4V. In most applications the LMH6515 input will need to be AC coupled.

The output common mode voltage is not self biasing, it needs to be pulled up to the positive supply rail with external inductors as shown in *Figure 1*. This gives the LMH6515 the capability for large signal swings with very low distortion on a single 5V supply. The internal load resistors provide the LMH6515 with very consistent gain.

A unique internal architecture allows the LMH6515 to be driven by either a differential or single ended source. If driving the LMH6515 single ended, the unused input should be terminated to ground with a 0.01 μF capacitor. Directly shorting the unused input to ground will disrupt the internal bias circuitry and will result in poor performance.

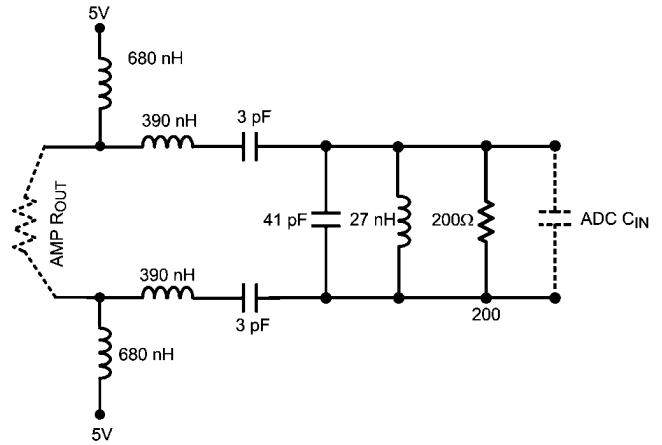

20214306

FIGURE 6. Bandpass Filter
 Center Frequency is 140 MHz with a 20 MHz Bandwidth
 Designed for 200Ω Impedance

ADC Noise Filter

Figure 6 shows a filter schematic and the following table of values are for some common IF frequencies. The filter shown offers a good compromise between bandwidth, noise rejection and cost. This filter topology is the same as used on the ADC14V155KDRB High IF Receiver reference design board. This filter topology works best with the 12 and 14-bit sub-sampling analog to digital converters shown in the *Compatible High Speed Analog to Digital Converters* table.

Filter Component Values

Filter Component Values					
	Fc	75 MHz	140 MHz	170 MHz	250 MHz
	BW	40 MHz	20 MHz	25 MHz	Narrow Band
Components	L1, L2	10 μH	10 μH	10 μH	10 μH
	L3, L4	390 nH	390 nH	560 nH	—
	C1, C2	10 pF	3 pF	1.4 pF	47 pF
	C3	22 pF	41 pF	32 pF	11 pF
	L5	220 nH	27 nH	30 nH	22 nH
	R1, R2	100	200	100	499

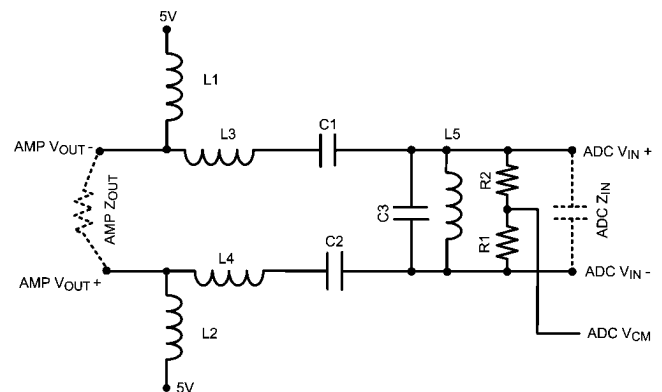

20214313

FIGURE 7. Sample Filter

POWER SUPPLIES

As shown in *Figure 8*, the LMH6515 has a number of options for power supply connections on the output pins. Pin 3 (V_{CC}) is always connected. The output stage can be connected as shown in *Figure 9*, *Figure 10*, or *Figure 11*. The supply voltage range for V_{CC} is 4V to 5.25V. A 5V supply provides the best performance while lower supplies will result in less power consumption. Power supply regulation of 2.5% or better is advised.

Of special note is that the digital circuits are powered from an internal supply voltage of 3.3V. The logic pins should not be driven above the absolute maximum value of 3.6V. See the Digital Control section for details.

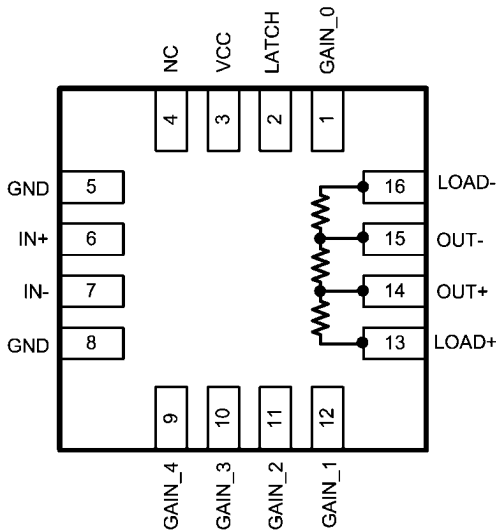

20214302

FIGURE 8. Internal Load Resistors

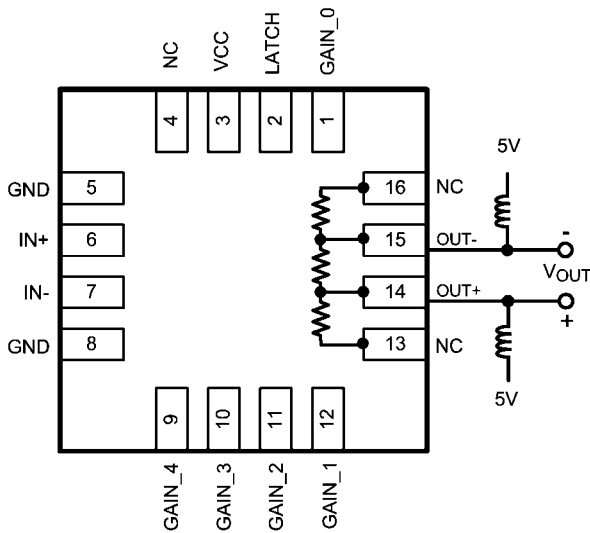

20214308

FIGURE 9. Using High Gain Mode (400Ω Load)

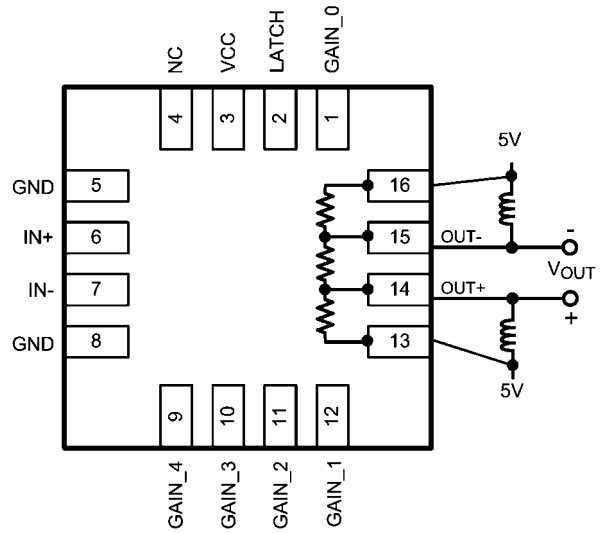

20214309

FIGURE 10. Using Low Gain Mode (200Ω Load)

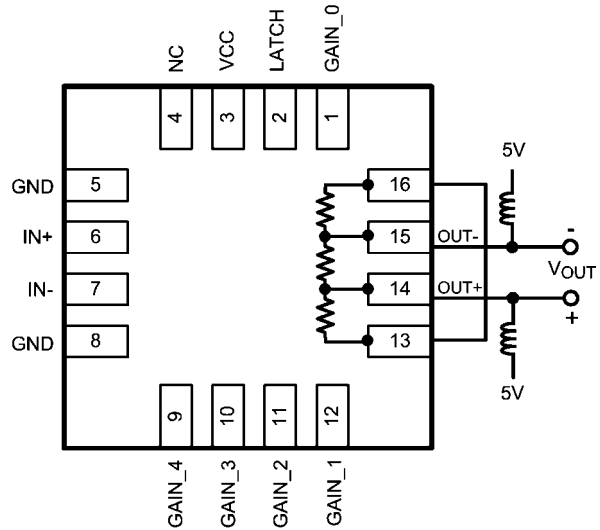

20214310

FIGURE 11. Alternate Connection for Low Gain Mode (200Ω Load)

Compatible High Speed Analog to Digital Converters

Product Number	Max Sampling Rate (MSPS)	Resolution	Channels
ADC12L063	62	12	SINGLE
ADC12DL065	65	12	DUAL
ADC12L066	66	12	SINGLE
ADC12DL066	66	12	DUAL
CLC5957	70	12	SINGLE
ADC12L080	80	12	SINGLE
ADC12DL080	80	12	DUAL
ADC12C080	80	12	SINGLE
ADC12C105	105	12	SINGLE
ADC12C170	170	12	SINGLE
ADC12V170	170	12	SINGLE
ADC14C080	80	14	SINGLE
ADC14C105	105	14	SINGLE
ADC14DS105	105	14	DUAL
ADC14155	155	14	SINGLE
ADC14V155	155	14	SINGLE
ADC08D500	500	8	DUAL
ADC08500	500	8	SINGLE
ADC08D1000	1000	8	DUAL
ADC081000	1000	8	SINGLE
ADC08D1500	1500	8	DUAL
ADC081500	1500	8	SINGLE
ADC08(B)3000	3000	8	SINGLE
ADC08L060	60	8	SINGLE
ADC08060	60	8	SINGLE
ADC10DL065	65	10	DUAL
ADC10065	65	10	SINGLE
ADC10080	80	10	SINGLE
ADC08100	100	8	SINGLE
ADCS9888	170	8	SINGLE
ADC08(B)200	200	8	SINGLE
ADC11C125	125	11	SINGLE
ADC11C170	170	11	SINGLE

Physical Dimensions inches (millimeters) unless otherwise noted

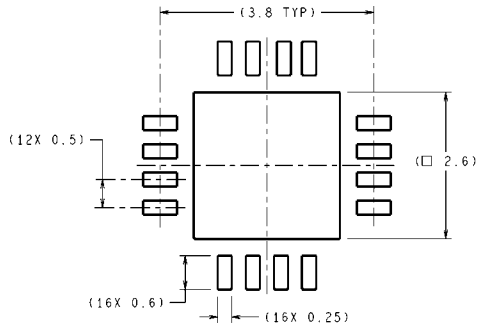

RECOMMENDED LAND PATTERN

DIMENSIONS ARE IN MILLIMETERS
DIMENSIONS IN () FOR REFERENCE ONLY

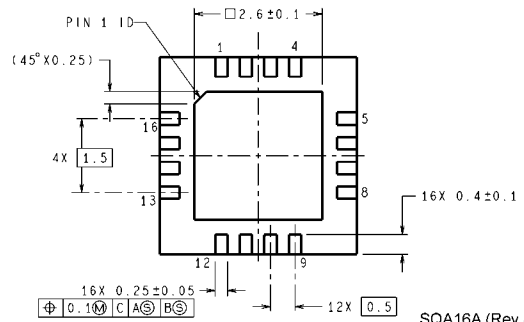
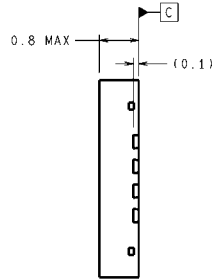
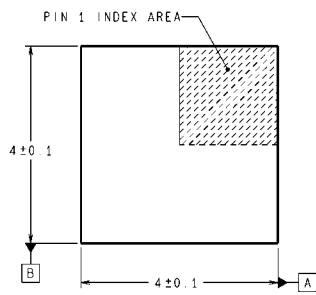

SQA16A (Rev A)

16-Pin Package
NS Package Number SQA16A

Notes

THE CONTENTS OF THIS DOCUMENT ARE PROVIDED IN CONNECTION WITH NATIONAL SEMICONDUCTOR CORPORATION ("NATIONAL") PRODUCTS. NATIONAL MAKES NO REPRESENTATIONS OR WARRANTIES WITH RESPECT TO THE ACCURACY OR COMPLETENESS OF THE CONTENTS OF THIS PUBLICATION AND RESERVES THE RIGHT TO MAKE CHANGES TO SPECIFICATIONS AND PRODUCT DESCRIPTIONS AT ANY TIME WITHOUT NOTICE. NO LICENSE, WHETHER EXPRESS, IMPLIED, ARISING BY ESTOPPEL OR OTHERWISE, TO ANY INTELLECTUAL PROPERTY RIGHTS IS GRANTED BY THIS DOCUMENT.

TESTING AND OTHER QUALITY CONTROLS ARE USED TO THE EXTENT NATIONAL DEEMS NECESSARY TO SUPPORT NATIONAL'S PRODUCT WARRANTY. EXCEPT WHERE MANDATED BY GOVERNMENT REQUIREMENTS, TESTING OF ALL PARAMETERS OF EACH PRODUCT IS NOT NECESSARILY PERFORMED. NATIONAL ASSUMES NO LIABILITY FOR APPLICATIONS ASSISTANCE OR BUYER PRODUCT DESIGN. BUYERS ARE RESPONSIBLE FOR THEIR PRODUCTS AND APPLICATIONS USING NATIONAL COMPONENTS. PRIOR TO USING OR DISTRIBUTING ANY PRODUCTS THAT INCLUDE NATIONAL COMPONENTS, BUYERS SHOULD PROVIDE ADEQUATE DESIGN, TESTING AND OPERATING SAFEGUARDS.

EXCEPT AS PROVIDED IN NATIONAL'S TERMS AND CONDITIONS OF SALE FOR SUCH PRODUCTS, NATIONAL ASSUMES NO LIABILITY WHATSOEVER, AND NATIONAL DISCLAIMS ANY EXPRESS OR IMPLIED WARRANTY RELATING TO THE SALE AND/OR USE OF NATIONAL PRODUCTS INCLUDING LIABILITY OR WARRANTIES RELATING TO FITNESS FOR A PARTICULAR PURPOSE, MERCHANTABILITY, OR INFRINGEMENT OF ANY PATENT, COPYRIGHT OR OTHER INTELLECTUAL PROPERTY RIGHT.

LIFE SUPPORT POLICY

NATIONAL'S PRODUCTS ARE NOT AUTHORIZED FOR USE AS CRITICAL COMPONENTS IN LIFE SUPPORT DEVICES OR SYSTEMS WITHOUT THE EXPRESS PRIOR WRITTEN APPROVAL OF THE CHIEF EXECUTIVE OFFICER AND GENERAL COUNSEL OF NATIONAL SEMICONDUCTOR CORPORATION. As used herein:

Life support devices or systems are devices which (a) are intended for surgical implant into the body, or (b) support or sustain life and whose failure to perform when properly used in accordance with instructions for use provided in the labeling can be reasonably expected to result in a significant injury to the user. A critical component is any component in a life support device or system whose failure to perform can be reasonably expected to cause the failure of the life support device or system or to affect its safety or effectiveness.

National Semiconductor and the National Semiconductor logo are registered trademarks of National Semiconductor Corporation. All other brand or product names may be trademarks or registered trademarks of their respective holders.

Copyright© 2007 National Semiconductor Corporation

For the most current product information visit us at www.national.com



**National Semiconductor
Americas Customer
Support Center**
Email:
new.feedback@nsc.com
Tel: 1-800-272-9959

**National Semiconductor Europe
Customer Support Center**
Fax: +49 (0) 180-530-85-86
Email: europe.support@nsc.com
Deutsch Tel: +49 (0) 69 9508 6208
English Tel: +49 (0) 870 24 0 2171
Français Tel: +33 (0) 1 41 91 8790

**National Semiconductor Asia
Pacific Customer Support Center**
Email: ap.support@nsc.com

**National Semiconductor Japan
Customer Support Center**
Fax: 81-3-5639-7507
Email: jpn.feedback@nsc.com
Tel: 81-3-5639-7560